

Pressure measurement

Process pressure/Hydrostatic

## VEGAWELL 72



## Product Information



**VEGA**

## Content

<b>1</b>	<b>Description of the measuring principle</b>	<b>3</b>
<b>2</b>	<b>Type overview</b>	<b>4</b>
<b>3</b>	<b>Mounting instructions</b>	<b>5</b>
<b>4</b>	<b>Electrical connection</b>	
4.1	General requirements	7
4.2	Voltage supply	7
4.3	Connection cable	7
4.4	Cable screening and grounding	7
4.5	Wiring plan VEGAWELL 72 - 4 ... 20 mA	7
4.6	Wiring plan VEGAWELL 72 - 4 ... 20 mA/HART	8
4.7	Wiring plan VEGAWELL 72 - 4 ... 20 mA/HART - Pt 100	8
<b>5</b>	<b>Operation</b>	
5.1	Overview	10
5.2	Adjustment with VEGADIS 12	10
5.3	Adjustment with PACTware	10
<b>6</b>	<b>Technical data</b>	<b>11</b>
<b>7</b>	<b>Dimensions</b>	<b>16</b>
<b>8</b>	<b>Product code</b>	<b>17</b>

### Take note of safety instructions for Ex applications



Please note the Ex specific safety information which you can find on our homepage [www.vega.com/services/downloads](http://www.vega.com/services/downloads) and which comes with every instrument. In hazardous areas you should take note of the appropriate regulations, conformity and type approval certificates of the sensors and power supply units. The sensors must only be operated on intrinsically safe circuits. The permissible electrical values are stated in the certificate.

# 1 Description of the measuring principle

## Measuring principle

VEGAWELL 72 pressure transmitters work according to the hydrostatic measuring principle, which functions independently of the dielectric properties of the product and is not influenced by foam generation.

The sensor element of VEGAWELL 72 is the dry ceramic-capacitive CERTEC<sup>®</sup> measuring cell. Base element and diaphragm consist of high purity sapphire-ceramic<sup>®</sup>.

The hydrostatic pressure of the product causes via the diaphragm a capacitance change in the measuring cell. This capacitance change is converted into an appropriate output signal.

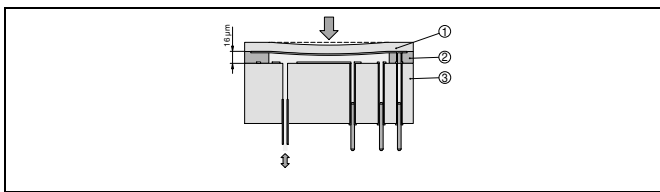

Fig. 1: Configuration of the CERTEC<sup>®</sup> measuring cell with VEGAWELL 72

- 1 Diaphragm
- 2 Soldered glass bond
- 3 Base element

The advantages of the CERTEC<sup>®</sup> measuring cell are:

- Very high overload resistance
- No hysteresis
- Excellent long-term stability
- Completely front flush installation
- Good corrosion resistance
- Very high abrasion resistance

## Wide application range

VEGAWELL 72 is suitable for level measurement in deep wells and ballast tanks as well as for gauge measurement in open flumes. Typical media are drinking water and waste water as well as water containing abrasive substances. All signal outputs are available in 4 ... 20 mA and 4 ... 20 mA/HART.

In the 4 ... 20 mA/HART - Pt 100 version, a temperature sensor Pt 100 in four-wire technology is optionally integrated in the transducer. Power supply or processing are carried out via an external temperature transducer.

## 2 Type overview

### VEGAWELL 72



Measuring cell:	CERTEC®
Media:	drinking water and waste water
Process fitting:	straining clamp, screwed fitting, thread, flange
Material process fitting:	316L
Material, suspension cable:	PE, PUR, FEP
Material transmitter:	316L, 316L with PE-coating, PVDF, Titanium
Diameter transmitter:	depending on material min. 32 mm
Measuring range:	0 ... 0.1 bar up to 0 ... 25 bar
Process temperature:	-20 ... +100 °C (-4 ... +212 °F)
Deviation:	< 0.2 %, < 0.25 %, < 0.1 %
Signal output:	4 ... 20 mA, 4 ... 20 mA/HART
Operation:	depending on the version via VEGADIS 12 or PACTware/PC

### 3 Mounting instructions

#### Mounting position

The following illustration shows a mounting example for VEGA-WELL 72. The VEGA price list contains suitable mounting brackets under the section Accessories. With these parts, standard mounting arrangements can be realised quickly and reliably.

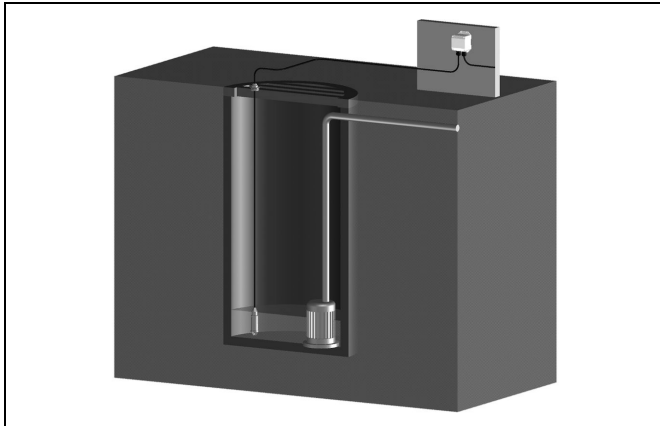

Fig. 2: Version with closing screw in a pump shaft

VEGAWELL 72 must be mounted in a calm area or in a suitable protective tube. This avoids lateral movements of the transmitter and the resulting corruption of measurement data.



**Note:**

As an alternative, we recommend using the instrument holder from the line of VEGA accessories, article no. BARMONT.B, to fasten the transmitter.

The suspension cable contains apart from the connection cables and the suspension wire also a capillary for atmospheric pressure compensation. All versions can be shortened on site.

With VEGAWELL 72, the electronics is completely integrated in the transmitter. The cable end can be lead directly to a dry connection compartment. Pressure compensation is then carried out via the filter element of the capillaries.



**Note:**

The pressure compensation housing VEGABOX 02 is recommended for connecting VEGAWELL 72.

It contains a high-quality ventilation filter and terminals. A protective cover is optionally available for use outdoors.

#### Mounting versions

The following illustrations show the different mounting versions depending on the instrument type.

#### Mounting with straining clamp

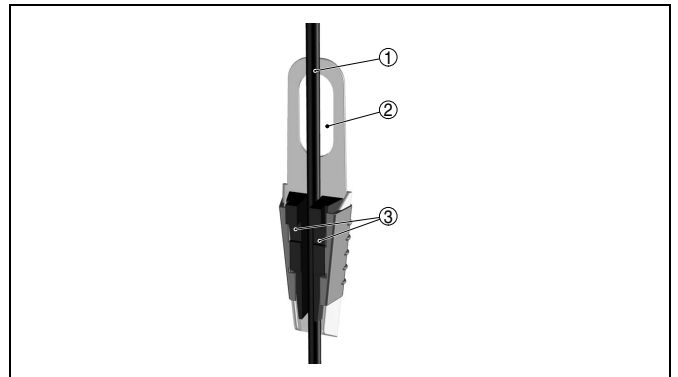

Fig. 3: Straining clamp

- 1 Suspension cable
- 2 Suspension opening
- 3 Clamping jaws

#### Mounting with screwed fitting

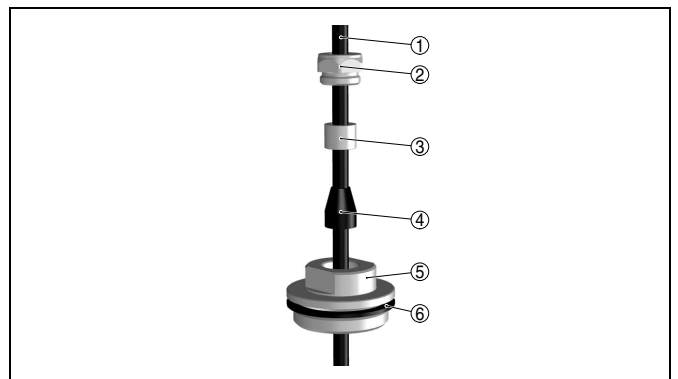

Fig. 4: Threaded fitting

- 1 Suspension cable
- 2 Seal screw
- 3 Cone bushing
- 4 Seal cone
- 5 Threaded fitting
- 6 Seal

**Mounting with housing and thread**

Fig. 5: Housing with thread G1½ A

- 1 Housing
- 2 Seal
- 3 Thread

## 4 Electrical connection

### 4.1 General requirements

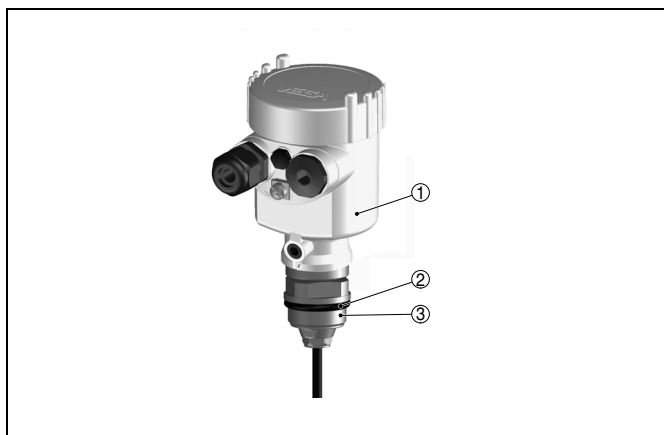
The supply voltage range can differ depending on the instrument version. You can find exact specifications in chapter "Technical data".

The national installation standards as well as the valid safety regulations and accident prevention rules must be observed.



In hazardous areas you should take note of the appropriate regulations, conformity and type approval certificates of the sensors and power supply units.

### 4.2 Voltage supply

Supply voltage and current signal are carried on the same two-wire cable. The requirements on the power supply are specified in chapter "Technical data".

The VEGA power supply units VEGATRENN 149AEx, VEGAS-TAB 690, VEGADIS 371 as well as VEGAMET signal conditioning instruments are suitable for power supply. When one of these instruments is used, a reliable separation of the supply circuits from the mains circuits according to DIN VDE 0106 part 101 is ensured.

### 4.3 Connection cable

#### In general

An outer diameter of 5 ... 9 mm ensures the seal effect of the cable entry. If electromagnetic interference is expected, screened cable should be used for the signal lines.

The sensors are connected with standard two-wire cable without screen.



In Ex applications, the corresponding installation regulations must be noted for the connection cable.

### 4.4 Cable screening and grounding

If screened cable is necessary, the cable screen must be connected on both ends to ground potential. If potential equalisation currents are expected, the connection on the evaluation side must be made via a ceramic capacitor (e.g. 1 nF, 1500 V).

### 4.5 Wiring plan VEGAWELL 72 - 4 ... 20 mA

#### Direct connection

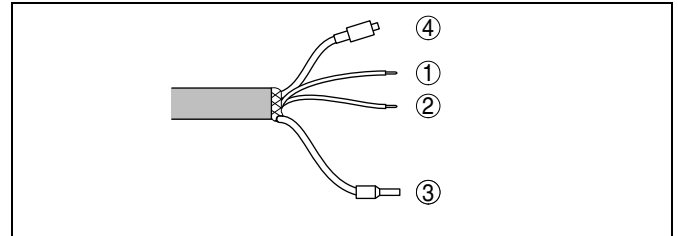

Fig. 6: Wire assignment, suspension cable

- 1 blue (-): to power supply or to the processing system
- 2 brown (+): to power supply or to the processing system
- 3 Shielding
- 4 Breather capillaries with filter element

#### Connection via VEGABOX 02

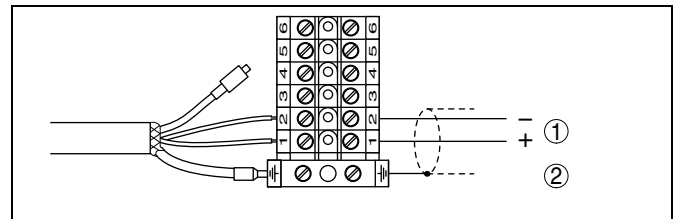

Fig. 7: Terminal assignment VEGABOX 02

- 1 To power supply or the processing system
- 2 Shielding<sup>1)</sup>

#### Connection via housing

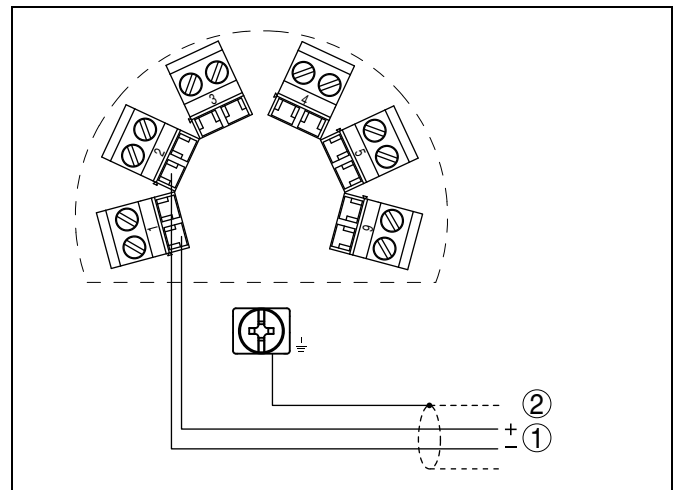

Fig. 8: Terminal assignment of the housing

- 1 To power supply or the processing system

<sup>1)</sup> Connect screen to ground terminal. Connect ground terminal on the outside of the housing as prescribed. The two terminals are galvanically connected.

### 4.6 Wiring plan VEGAWELL 72 - 4 ... 20 mA/ HART

#### Direct connection

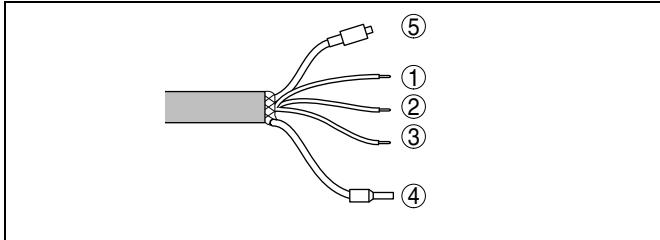

Fig. 9: Wire assignment, connection cable

- 1 brown (+): to power supply or to the processing system
- 2 blue (-): to power supply or to the processing system
- 3 yellow: is only required with VEGADIS 12, otherwise connect to minus or with VEGABOX 02 to terminal 3<sup>2)</sup>
- 4 Shielding
- 5 Breather capillaries with filter element

#### Connection via VEGADIS 12

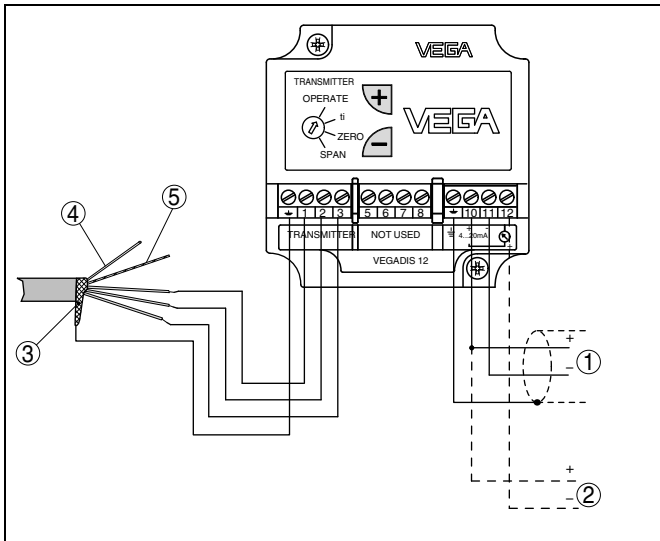

Fig. 10: Terminal assignment, VEGADIS 12

- 1 Voltage supply and signal output
- 2 Control instrument (4 ... 20 mA measurement)

<sup>2)</sup> For customer-specific versions, already connected with blue (-) when shipped.

#### Connection via housing

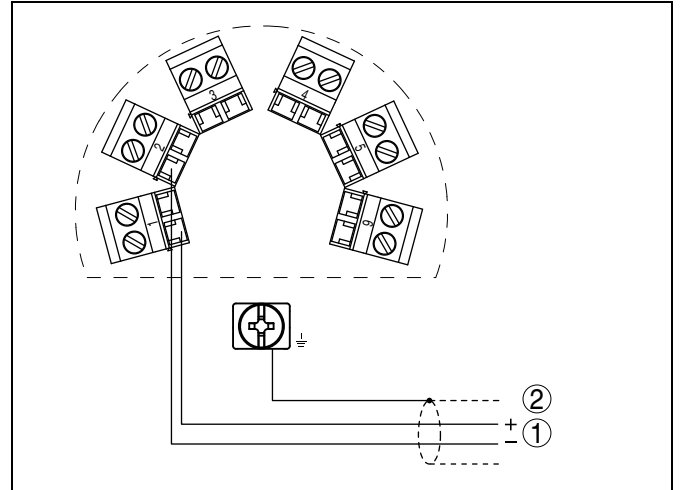

Fig. 11: Terminal assignment of the housing

- 1 To power supply or the processing system

### 4.7 Wiring plan VEGAWELL 72 - 4 ... 20 mA/ HART - Pt 100

#### Direct connection

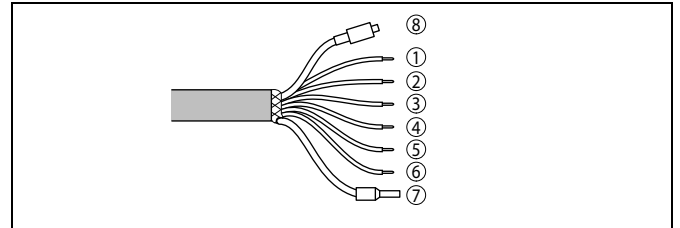

Fig. 12: Wire assignment, connection cable

- 1 blue (-): to power supply or to the processing system
- 2 brown (+): to power supply or to the processing system
- 3 white: for processing of the integrated Pt 100 (power supply)
- 4 Yellow: for processing of the integrated Pt 100 (measurement)
- 5 Red: for processing of the integrated Pt 100 (measurement)
- 6 Black: for processing of the integrated Pt 100 (power supply)
- 7 Shielding
- 8 Breather capillaries with filter element

## Connection via VEGABOX 02

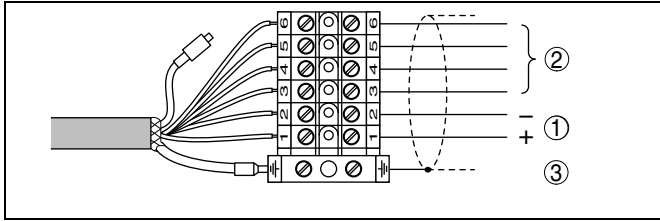

Fig. 13: Terminal assignment VEGABOX 02

- 1 To power supply or the processing system (signal pressure transmitter)
- 2 To power supply or the processing system (connection cables resistance thermometer Pt 100)
- 3 Shielding<sup>3)</sup>

## Connection via VEGABOX 02 with integrated temperature sensor

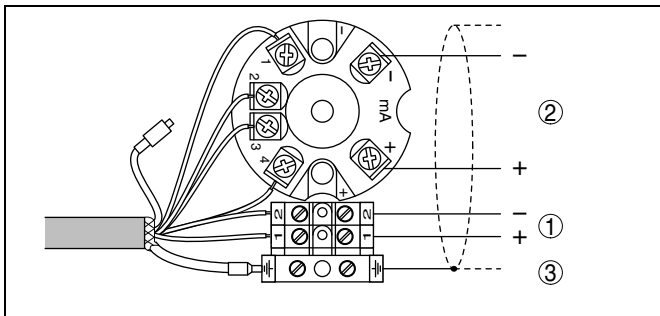

Fig. 14: Terminal assignment VEGABOX 02

- 1 To power supply or the processing system (signal pressure transmitter)
- 2 For voltage supply or to processing system (resistance thermometer Pt 100)
- 3 Shielding<sup>4)</sup>

## Connection via housing

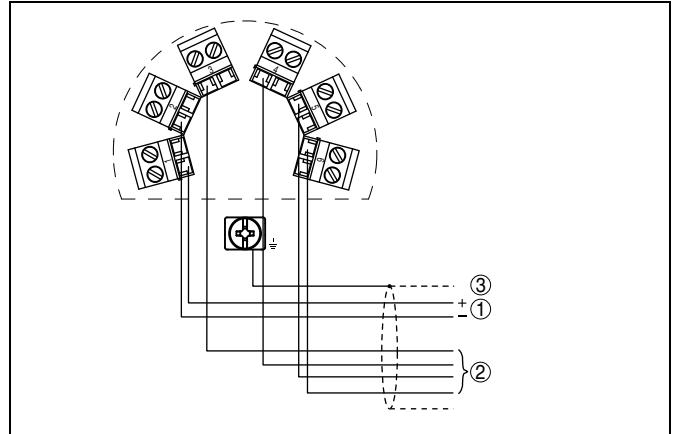

Fig. 15: Terminal assignment of the housing

- 1 To power supply or the processing system (signal pressure transmitter)
- 2 For voltage supply or to processing system (resistance thermometer Pt 100)
- 3 Shielding<sup>5)</sup>

<sup>3)</sup> Connect screen to ground terminal. Connect ground terminal on the outside of the housing as prescribed. The two terminals are galvanically connected.

<sup>4)</sup> Connect screen to ground terminal. Connect ground terminal on the outside of the housing as prescribed. The two terminals are galvanically connected.

<sup>5)</sup> Connect screen to ground terminal. Connect ground terminal on the outside of the housing as prescribed. The two terminals are galvanically connected.

## 5 Operation

### 5.1 Overview

#### VEGAWELL 72 4 ... 20 mA

VEGAWELL 72 - 4 ... 20 mA has no adjustment options.

#### VEGAWELL 72 4 ... 20 mA/HART

- Indication/Adjustment VEGADIS 12
- Adjustment software according to FDT/DTM standard, e.g. PACTware and PC
- HART handheld

#### VEGAWELL 72 4 ... 20 mA/HART - PT 100

- Adjustment software according to FDT/DTM standard, e.g. PACTware and PC
- HART handheld

### 5.2 Adjustment with VEGADIS 12

VEGADIS 12 is connected directly to the connection or suspension cable of VEGAWELL 72 - 4 ... 20 mA/HART. It is looped into the supply and signal circuit and requires no separate external energy.

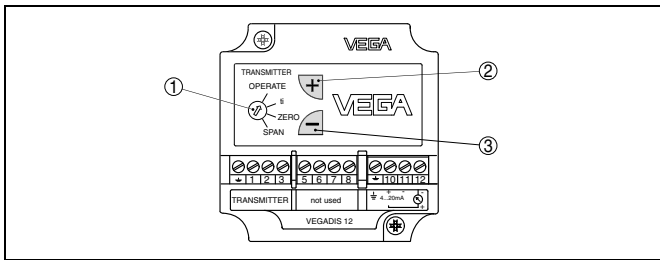

Fig. 16: Adjustment elements of VEGADIS 12

- 1 Rotary switch: choose the requested function
- 2 [+] key change value
- 3 [-] key change value

### 5.3 Adjustment with PACTware

#### Connecting the PC to the signal cable

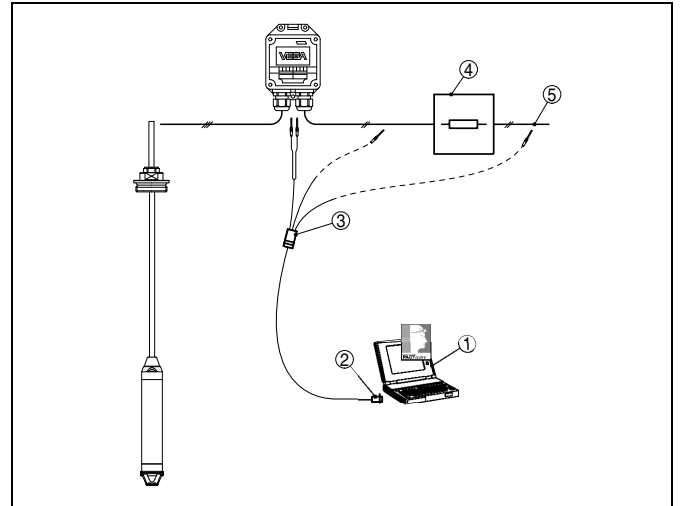

Fig. 17: Connection of the PC to VEGADIS 12 or to the communication resistor

- 1 PC with PACTware
- 2 RS232 connection
- 3 VEGACONNECT
- 4 Communication resistor 250 Ω
- 5 Power supply unit

#### Necessary components:

- VEGAWELL 72
- PC with PACTware and suitable VEGA DTM
- VEGACONNECT with HART adapter cable
- HART resistor approx. 250 Ω
- Power supply unit



#### Note:

With power supply units with integrated HART resistance (internal resistance approx. 250 Ω), an additional external resistance is not necessary (e. g. VEGATRENN 149A, VEGAMET 381/624/625, VEGASCAN 693). In such cases, VEGACONNECT can be connected parallel to the 4 ... 20 mA cable.

## 6 Technical data

### Materials and weights

Materials, wetted parts	
– Transmitter	316L, 316L with PE coating, 1.4462, 1.4462 with PE coating, PVDF, Titanium
– Protective cap	PA, PE
– Diaphragm	sapphire ceramic® (99.9 % oxide ceramic)
– Measuring cell seal	FKM (FDA and KTW approved), FFKM
– Suspension cable	PE (FDA and KTW-approved), FEP, PUR
– Cable gland on the transmitter	316L
– Cable seal with PE, PUR cable	FKM
– Cable seal with FEP cable	FEP
– Process fitting	316L
– Straining clamp	1.4301
– Unassembled threaded fitting	316L, PVDF
– Threaded connection on the housing	316L
Materials, non-wetted parts	
– Housing	plastic PBT (Polyester), 316L
– type label support on cable	PE hard
– transport protection net	PE
Weight approx.	
– Basic weight	0.8 kg (1.764 lbs)
– Suspension cable	0.1 kg/m (0.07 lbs/ft)
– Straining clamp	0.2 kg (0.441 lbs)
– Threaded fitting	0.4 kg (0.882 lbs)
– Plastic housing	0.8 kg (1.764 lbs)

### Input variable

Measured value	Level
Measuring range	see product code
Recommended max. turn down	10 : 1

### Output variable

<b>4 ... 20 mA</b>	
Output signal	4 ... 20 mA
Signal resolution	2 µA
Failure signal	22 mA
Max. output current	22 mA
Run-up time	2 s
Step response time	100 ms (ti: 0 s, 0 ... 63 %)
Fulfilled NAMUR recommendations	NE 43
<b>4 ... 20 mA/HART, 4 ... 20 mA/HART - PT 100</b>	
Output signal	4 ... 20 mA/HART
Signal resolution	2 µA
Failure signal	< 3.6 mA; 20.5 mA; 22 mA; unchanged (adjustable via PACTware)
Max. output current	22 mA
Run-up time	15 s
Step response time	200 ms (ti: 0 s, 0 ... 63 %)
Fulfilled NAMUR recommendations	NE 43

### Additional output parameter - temperature

integrated resistance thermometer	Pt 100 according to DIN EN 60751
Range	-50 ... +100 °C (-58 ... +212 °F)
Resolution	1 °K

### Deviation for 4 ... 20 mA version<sup>6)</sup>

Specifications refer to the set span. Turn down (TD) = nominal measuring range/set span.

<sup>6)</sup> Determined according to the limit point method according to IEC 60770, incl. non-linearity, hysteresis and non-repeatability.

Deviation

- Turn down 1 : 1 up to 5 : 1 < 0.2 %
- Turn down > 10 : 1 < 0.04 % x TD

**Deviation for 4 ... 20 mA/HART and 4 ... 20 mA/HART - Pt 100 version<sup>7)</sup>**

Applies to **digital** HART interface as well as to **analogue** current output 4 ... 20 mA. Specifications refer to the set span. Turn down (TD) is the relation nominal measuring range/set span.

- Deviation with version < 0.25 %
- Turn down 1 : 1 up to 5 : 1 < 0.25 %
  - Turn down > 10 : 1 < 0.25 % x TD
- Deviation with version < 0.1 %
- Turn down 1 : 1 up to 5 : 1 < 0.1 %
  - Turn down > 10 : 1 < 0.02 % x TD

**Influence of the product or ambient temperature**

Applies to **digital** HART interface as well as to **analogue** current output 4 ... 20 mA. Specifications refer to the set span. Turn down (TD) is the relation nominal measuring range/set span.

**Average temperature coefficient of the zero signal**

In the compensated temperature range of 0 ... +80 °C (+32 ... +176 °F), reference temperature 20 °C (68 °F).

- Average temperature coefficient of the zero signal
- Turn down 1 : 1 < 0.05 %/10 K
  - Turn down 1 : 1 up to 5 : 1 < 0.1 %/10 K
  - Turn down > 10 : 1 < 0.15 %/10 K

Outside the compensated temperature range

- Average temperature coefficient of the zero signal
- Turn down 1 : 1 typ. < 0.05 %/10 K

**Thermal change of the current output**

Applies also to the **analogue** 4 ... 20 mA current output and refers to the set span.

- Thermal change, current output < 0.15 % at -40 ... +80 °C (-40 ... +176 °F)

**Long-term stability (similar to DIN 16086, DINV 19259-1 and IEC 60770-1)**

Applies to **digital** HART interface as well as to **analogue** current output 4 ... 20 mA. Specifications refer to the set span. Turn down (TD) is the relation nominal measuring range/set span.

- Long-term drift of the zero signal < (0.1 % x TD)/year

**Ambient conditions**

- Ambient temperature
- Connection cable PE -40 ... +60 °C (-40 ... +140 °F)
  - Connection cable PUR, FEP -40 ... +85 °C (-40 ... +185 °F)
  - Storage and transport temperature -20 ... +80 °C (-4 ... +176 °F)

**Process conditions**

**Process pressure**

- Max. process pressure, transmitter
- with measuring ranges 0.1 bar (1.45 psig) or 0.2 bar (2.9 psig) max. 15 bar (217.6 psig) or max. 20 bar (290 psig)<sup>8)</sup>
  - with meas. ranges from 0.4 bar (5.8 psig) 25 bar (363 psig)<sup>9)</sup>
- Pressure stage, process fitting
- Unassembled threaded fitting 316L: PN 3, PVDF: unpressurized
  - Thread on the housing PN 3

<sup>7)</sup> Determined according to the limit point method according to IEC 60770, incl. non-linearity, hysteresis and non-repeatability.  
<sup>8)</sup> Limited by the overpressure resistance of the measuring cell.  
<sup>9)</sup> Limitation by the pressure-tightness of the cable connection.

Suspension cable	Measuring cell seal	Product temperature
PE	FKM	-20 ... +60 °C (-4 ... +140 °F)
PUR	FKM	-20 ... +80 °C (-4 ... +176 °F)
PUR	FFKM	-20 ... +80 °C (-4 ... +176 °F)
FEP	FFKM	-10 ... +80 °C (+14 ... +176 °F)

Connection tube	Measuring cell seal	Product temperature
316L	FFKM	-20 ... +80 °C (-4 ... +212 °F)

Transmitter protection	Measuring cell seal	Product temperature
PVDF	FFKM	-10 ... +60 °C (14 ... +140 °F)
PE	FKM	-20 ... +60 °C (-4 ... +140 °F)
PE	FFKM	-10 ... +60 °C (+14 ... +140 °F)

Vibration resistance

mechanical vibrations with 4 g and 5 ... 100 Hz<sup>10)</sup>

### Electromechanical data

Suspension cable	four wires, one suspension cable, one breather capillary, screen braiding, foil, mantle
– Configuration	
– Wire cross-section	0.5 mm <sup>2</sup> (AWG 20)
– Wire resistance	≤ 0.036 Ω/m
– Tensile strength	≥ 1200 N (270 pound force)
– Max. length	1000 m (3280 ft) <sup>11)</sup>
– Min. bending radius	25 mm (with 25 °C/77 °F)
– Diameter approx.	8 mm (0.315 in)
– colour (non-Ex/Ex) - PE	black/blue
– colour (non-Ex/Ex) - PUR, FEP	blue/blue
Cable entry, housing or VEGABOX 02/VEGADIS 12	1 x cable gland M20 x 1.5 (cable: ø 5 ... 9 mm), 1 x blind stopper M20 x 1.5
Screw terminals	for wire cross section 1.5 mm <sup>2</sup> (AWG 16), screen up to 4 mm <sup>2</sup> (AWG 12)

### Supply voltage - 4 ... 20 mA

Supply voltage	
– Non-Ex instrument	9.6 ... 36 V DC
– EEx-ia instrument	9.6 ... 29 V DC
Permissible residual ripple	
– < 100 Hz	U <sub>ss</sub> < 1 V
– 100 Hz ... 10 kHz	U <sub>ss</sub> < 10 mV
Load	see diagram

<sup>10)</sup> Tested according to the regulations of German Lloyd, GL directive 2.

<sup>11)</sup> With VEGADIS 12: 200 m (656 ft).

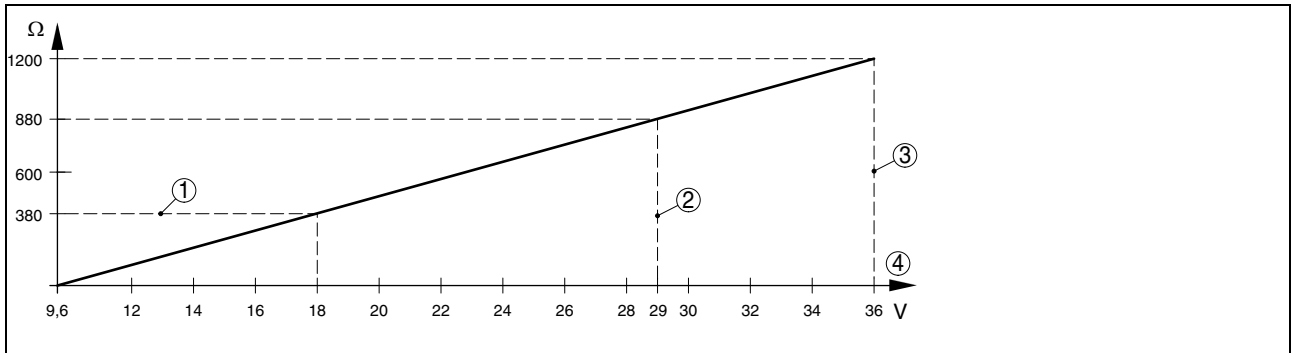

Fig. 18: Voltage diagram

- 1 meaningless
- 2 Voltage limit Ex instrument
- 3 Voltage limit non-Ex instrument
- 4 Supply voltage

**Supply voltage - 4 ... 20 mA/HART**

- |                             |                  |
|-----------------------------|------------------|
| Supply voltage              |                  |
| - Non-Ex instrument         | 12 ... 36 V DC   |
| - EEx-ia instrument         | 12 ... 29 V DC   |
| Permissible residual ripple |                  |
| - < 100 Hz                  | $U_{ss} < 1 V$   |
| - 100 Hz ... 10 kHz         | $U_{ss} < 10 mV$ |
| Load                        | see diagram      |

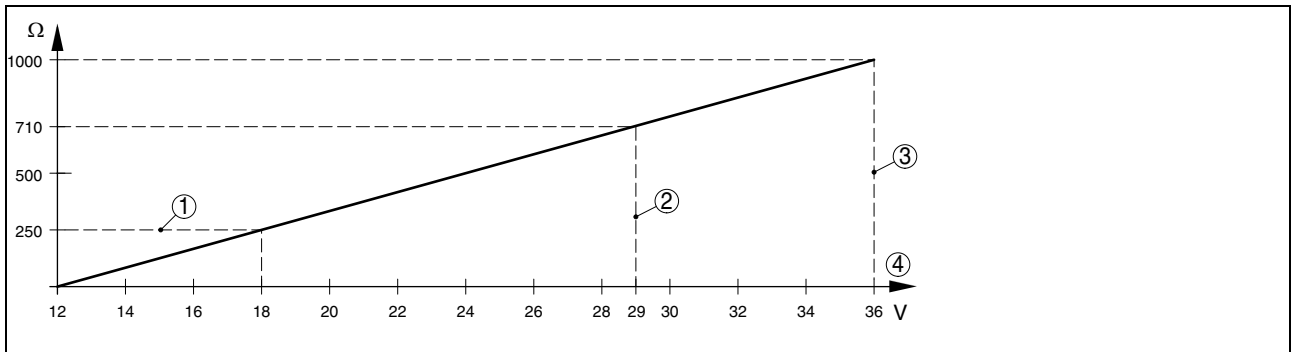

Fig. 19: Voltage diagram 4 ... 20 mA/HART

- 1 HART load
- 2 Voltage limit Ex instrument
- 3 Voltage limit non-Ex instrument
- 4 Supply voltage

**Supply voltage - 4 ... 20 mA/HART - Pt 100**

- |                             |                  |
|-----------------------------|------------------|
| Supply voltage              |                  |
| - Non-Ex instrument         | 9.6 ... 36 V DC  |
| - EEx-ia instrument         | 9.6 ... 30 V DC  |
| Permissible residual ripple |                  |
| - < 100 Hz                  | $U_{ss} < 1 V$   |
| - 100 Hz ... 10 kHz         | $U_{ss} < 10 mV$ |
| Load                        | see diagram      |

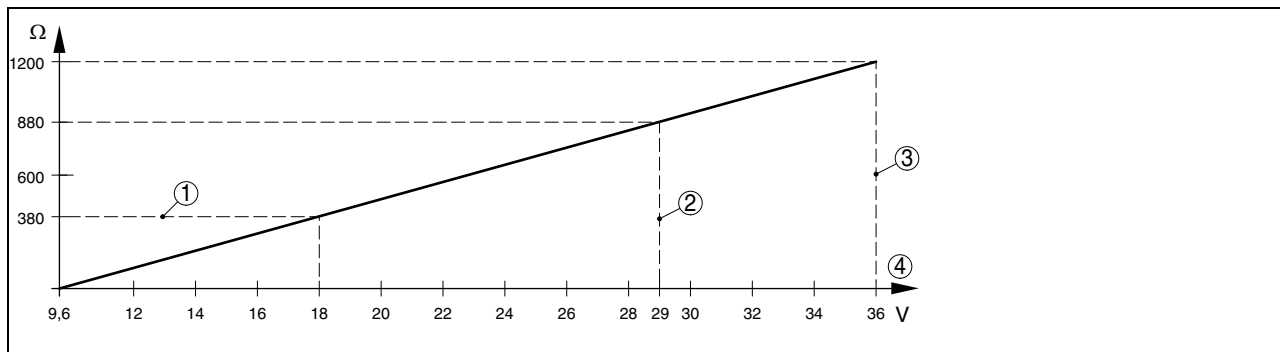

Fig. 20: Voltage diagram

- 1 HART load
- 2 Voltage limit Ex instrument
- 3 Voltage limit non-Ex instrument
- 4 Supply voltage

**Electrical protective measures**

Protection	
- Transmitter	IP 68 (25 bar)
- Housing	IP 66/IP 67
- VEGABOX 02, VEGADIS 12	IP 65
Overvoltage category	III
Protection class	III

**Existing approvals or approvals applied for<sup>12)13)</sup>**

ATEX	ATEX II 2G EEx ia IIC T6
IEC	IEC Ex ia IIC T6
PTB	Ex-Zone 2
Ship approvals	GL, LRS, ABS, CCS, RINA, DNV
Others	WHG

**CE conformity**

EMC (89/336/EWG)	Emission EN 61326: 1997/A1: 1998 (class B), susceptibility EN 61326: 1997/A1: 1998
LVD (73/23/EWG)	EN 61010-1: 1993

**Environmental instructions**

VEGA environment management system certified according to DIN EN ISO 14001  
 You can find detailed information under [www.vega.com](http://www.vega.com).

30046-EN-080806

<sup>12)</sup> Deviating data in Ex applications: see separate safety instructions.  
<sup>13)</sup> You can find detailed information under [www.vega.com](http://www.vega.com).

## 7 Dimensions

### VEGAWELL 72 - suspension cable

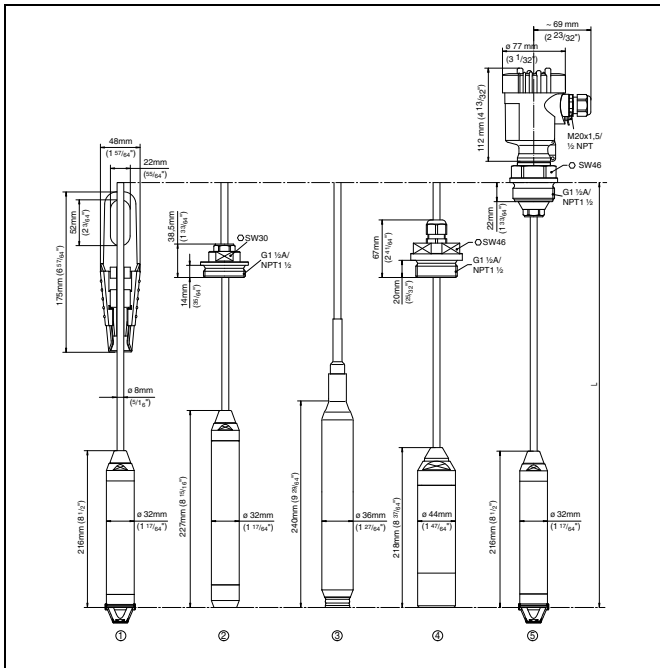

Fig. 21: VEGAWELL 72 - 4 ... 20 mA/HART - suspension cable

- 1 with straining clamp
- 2 Deep well version with unassembled threaded fitting G1½ A (1½ NPT) and closing cap
- 3 with PE plastic coating
- 4 Transmitter with screwed connection of PVDF
- 5 With thread G1½ A (1½ NPT) and housing









**VEGA**

VEGA Grieshaber KG  
Am Hohenstein 113  
77761 Schiltach  
Germany  
Phone +49 7836 50-0  
Fax +49 7836 50-201  
E-Mail: [info@de.vega.com](mailto:info@de.vega.com)  
[www.vega.com](http://www.vega.com)



You can find at [www.vega.com](http://www.vega.com)  
downloads of the following

- operating instructions manuals
- menu schematics
- software
- certificates
- approvals

and much, much more