

VEGAFLEX 63

Foundation Fieldbus

TDR sensor for continuous level measurement



Application area

VEGAFLEX 63 is a level sensor for continuous level measurement. It is suitable for liquids in practically all areas of industry.

Typical applications are measurements of aggressive and corrosive liquids as well as applications in the food processing/pharmaceutical industry.

All instruments are preset to the ordered sensor length.

Advantages

- Easy setup without adjustment
- Independent of product properties
- Insensitive to dust, vapour, buildup and condensation
- Good cleanability and very high chemical resistance
- High accuracy
- SIL qualified

Function

High frequency microwave pulses are coupled onto a cable or rod and guided along the probe. The pulses are reflected by the product surface. The time from emission to reception of the signals is proportional to the level in the vessel.

Technical data

Measuring range

- Rod version up to 4 m (13.12 ft)
- Cable version up to 32 m (105 ft)

Measuring accuracy ± 3 mm

Process fitting Flanges from DN 25, Tri-Clamp from 1½", bolting from DN 32

Process pressure -0.5 ... +16 bar/-50 ... +1600 kPa (-7.3 ... +232 psig)

Process temperature -40 ... +150 °C (-40 ... +302 °F)

Ambient, storage and transport temperature -40 ... +80 °C (-40 ... +176 °F)

Operating voltage 9 ... 32 V DC

Materials

The wetted parts of the instrument are fully PFA insulated.

You can find a complete overview of the available materials and seals in the "configurator" on our homepage at www.vega.com/configurator.

Housing versions

The housings are available as single chamber or double chamber version in plastic, stainless steel or aluminium.

They are available in protection ratings up to IP 68 (1 bar).

Electronics versions

The instruments are available in different electronics versions. Apart from the two-wire electronics with 4 ... 20 mA/HART, a four-wire version and two purely digital versions with Profibus PA and Foundation Fieldbus are available.

Approvals

The instruments are suitable for use in hazardous areas and are approved e.g. according to ATEX and IEC. The instruments have also different ship approvals such as e.g. GL, LRS or ABS.

You can find detailed information on the existing approvals in the "configurator" on our homepage under www.vega.com/configurator.

Operation

The adjustment of the instrument is carried out via the optional indicating and adjustment module PLICSCOM or via a PC with the adjustment software PACTware and respective DTM. Another adjustment possibility is a configuration tool for Foundation Fieldbus instruments.

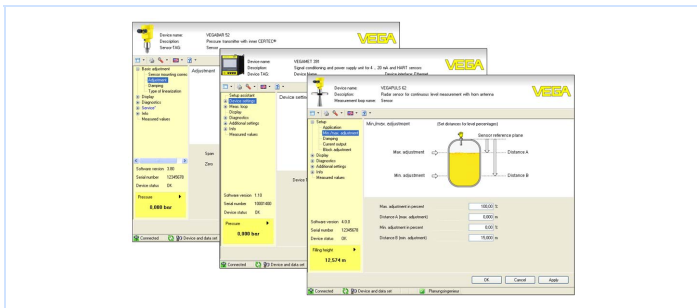

Electrical connection

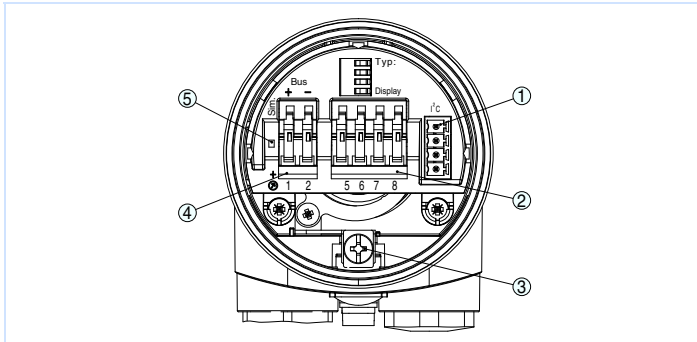

Electronics and connection compartment, single chamber housing

- 1 Plug connector for VEGACONNECT (I²C interface)
- 2 Spring-loaded terminals for connection of the external indication VEGADIS 61
- 3 Ground terminal for connection of the cable screen
- 4 Spring-loaded terminals for voltage supply
- 5 Simulation switch ("on" = mode for simulation release)

You can find details on the electrical connection in chapter "Connecting to power supply" in the operating instructions of the instrument. You can download the operating instructions from our homepage at www.vega.com/downloads.

Dimensions

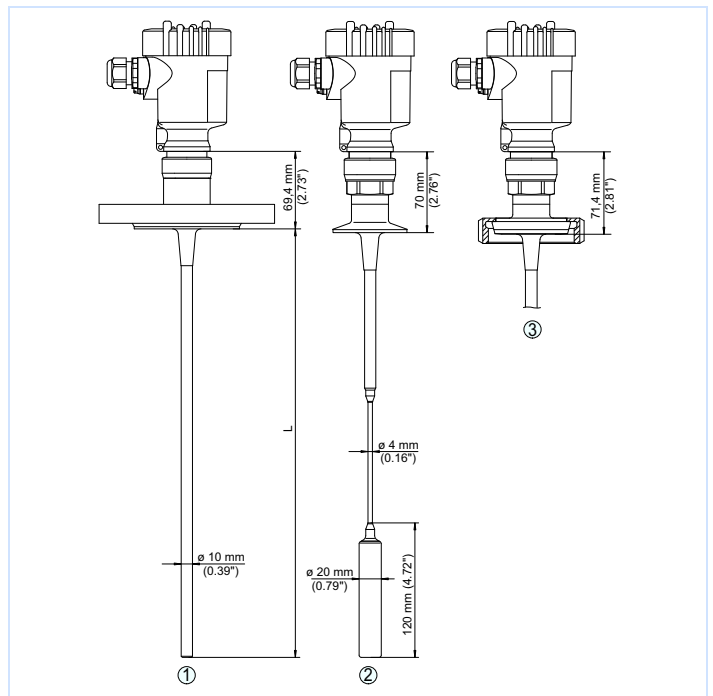

VEGAFLEX 63

- 1 Rod version with flange connection
- 2 Cable version with Tri-Clamp
- 3 Instrument version with bolting

Information

You can find further information about the VEGA product line on our homepage www.vega.com. In the download section under www.vega.com/downloads you'll find free operating instructions, product information, brochures, approval documents, instrument drawings and much, much more. There, you will also find GSD and EDD files for Profibus PA systems as well as DD and CFF files for Foundation Fieldbus systems.

Instrument selection

With the "finder" you can select the most suitable measuring principle for your application: www.vega.com/finder. You can find detailed information on the instrument versions in the "configurator" on our homepage under www.vega.com/configurator.

Contact

You can find the VEGA agency serving your area on our homepage www.vega.com.